

HERNON® MANUFACTURING, INC.

HIGH PERFORMANCE ADHESIVES, SEALANTS
AND PRECISION APPLICATION SOLUTIONS

121 TECH DRIVE
SANFORD, FL 32711

HERNON.COM

PH: 800-527-0004 / 407-322-4000

ISO-9001 MADE IN USA

ULTRACURE® 1100 DATA SHEET

EDS_UC1100_3

UV LED CONVEYOR CURING SYSTEM



UC1100 Features/Specifications:

- Benchtop Conveyor UV Curing Unit
- High Intensity UV LED (365nm)
- Variable Intensity Control
- Color Touchscreen HMI
- 100-240 vac, 50/60hz
- Conveyor Speed Range: 0.1" to 2.6"/second
- Conveyor Belt Direction Reversible
- Maximum Load Weight: 30lbs
- Easily Adjustable UV LED Elevator (3" Stroke)
- Specially Designed Teflon® Coated Kevlar® Belt
- Integrated Heat Exchanger For UV LED Units
- Integrated Exhaust Blower/Filter Assists With Cooling
- Heavy Duty All Aluminum Construction
- Machine Dimensions: 20"W x 21"T x 54"L
- Conveyor Dimensions: 8"W x 3"T x 41"L
- UV Curing Window Area = 6"W x 3"T x 6"L
- Weight: 117 lbs

FRONT VIEW

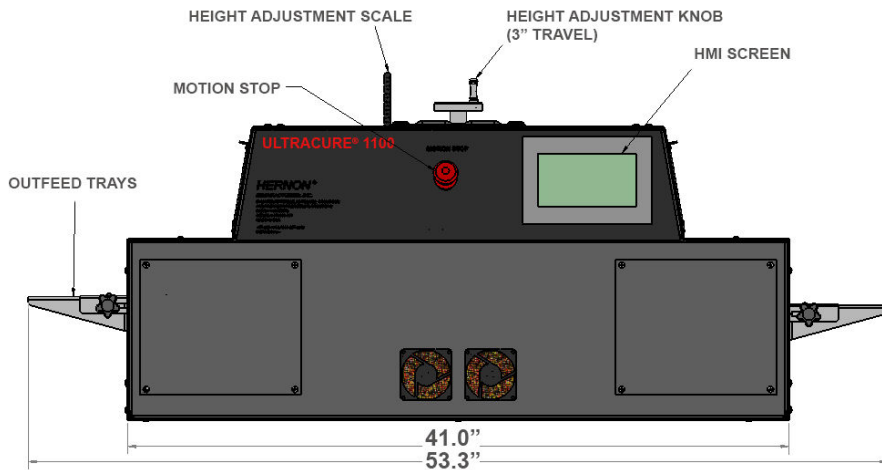

SIDE VIEW

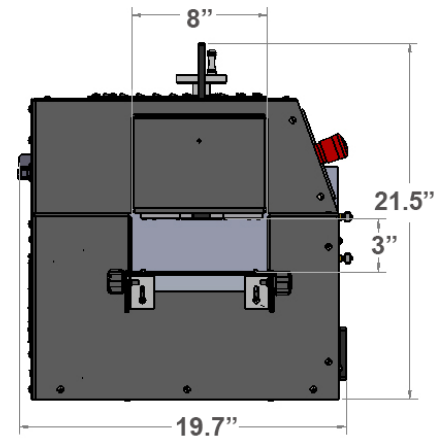

HEAT EXCHANGE

